

ISS.	MN/PRN/DN	ACTION	APPR'D	DATE
1	DN/E/144	JP		
-	-	-	-	-
-	-	-	-	-

RECOMMENDED HEIGHT OF FOOTPRINT FOR SERVICE FUNCTIONS.

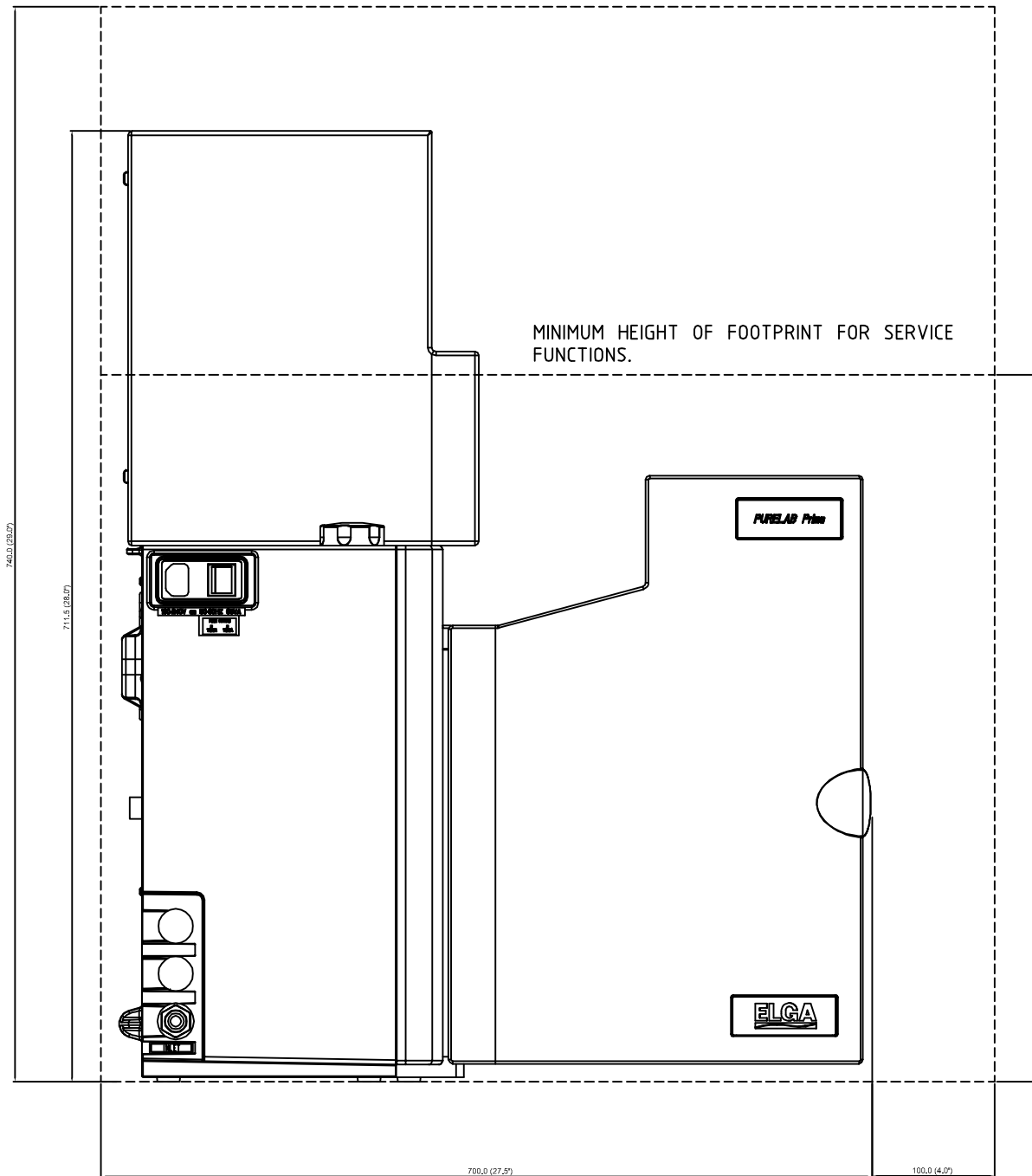

MINIMUM HEIGHT OF FOOTPRINT FOR SERVICE FUNCTIONS.

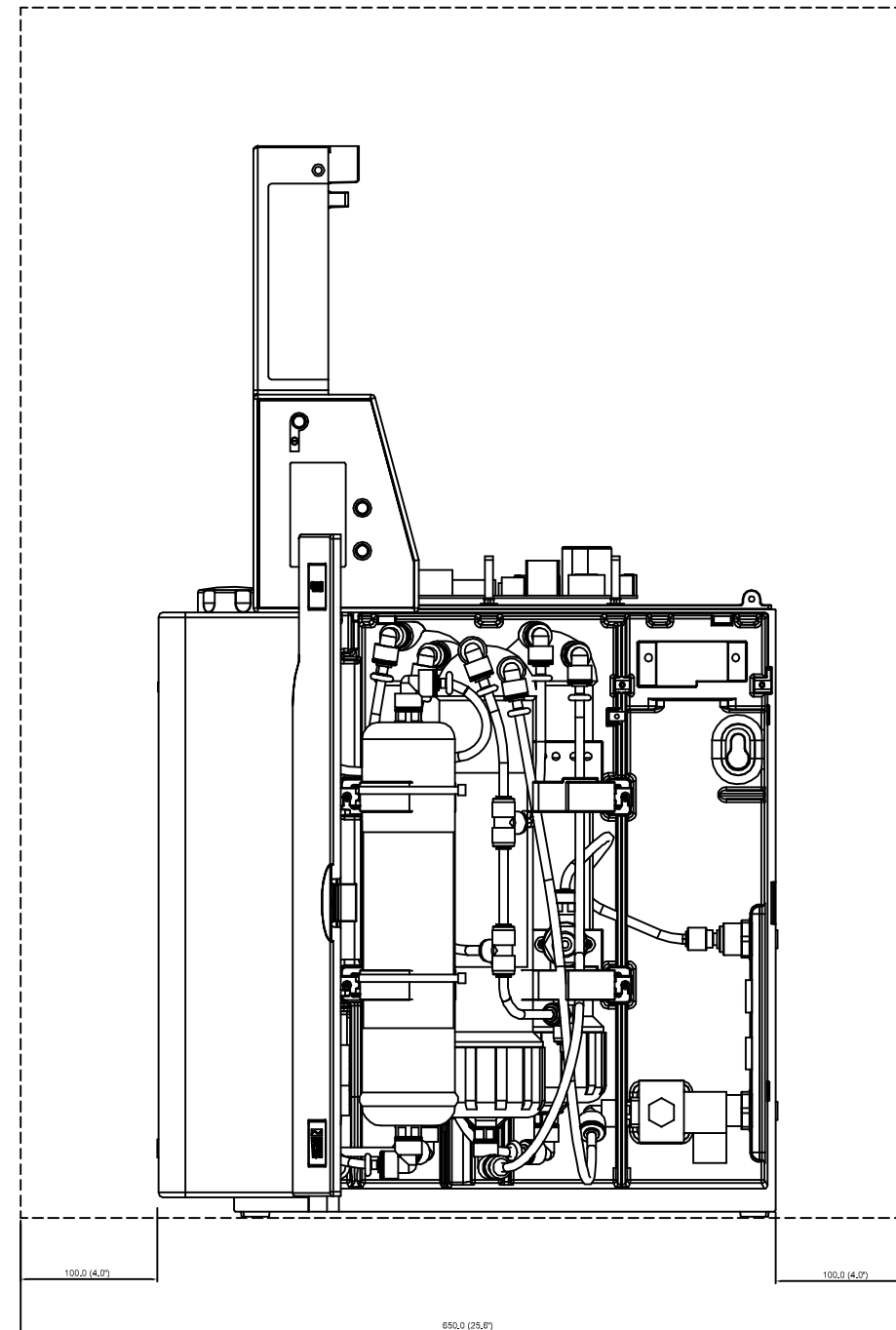

NOTE:-

TOP OF THE UNIT IS SHOWN OPEN TO ENSURE SUFFICIENT ACCESS FOR THE PERFORMANCE OF SERVICE FUNCTIONS.

IF IN DOUBT-ASK

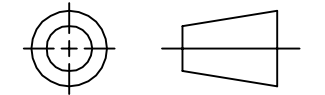

3rd ANGLE PROJECTION DO NOT SCALE

MATERIAL: N/A

FINISH: N/A

GENERAL NOTE: N/A

TOLERANCES UNLESS STATED:
 ONE PLACE DEC. \pm N/A ANGULAR $\pm 0.5^\circ$
 TWO PLACE DEC. \pm ALL HOLE TOLS. TO BS.4500 H11

DIMS. IN mm	SCALE	DRAWN	JP	AUG 11	DATE
		CHECKED	SB	AUG 11	
SIZE: A3	NTS	APPROVED	LU	AUG 11	

TITLE
**SALES DIAGRAM
 RECOM'D FOOTPRINT
 PURELAB PRIMA
 7/15/30**

PART NUMBER: N/A

ELGA

www.elgalabwater.com

info@elgalabwater.com

ELGA is the laboratory water brand of Veolia Water Solutions & Technologies.

DRG. NO.	SD_PP_002	ISSUE	1
SHEET No.2 OF 3			

THIS DRAWING IS THE PROPERTY OF ELGA Labwater. THE DETAILS SHOWN ARE STRICTLY CONFIDENTIAL AND MUST NOT BE DISCLOSED TO ANY THIRD PARTY WITHOUT THE CONSENT OF VWS (UK) LTD.