

| ISS. | MN/PRN/DN | ACTION | APPR'D | DATE    |
|------|-----------|--------|--------|---------|
| 1    | DN/E/127  | BAC    | LU     | MAY 09  |
| 6    | DN/E/144  | DSS    | SBT    | SEPT 11 |
| -    | -         | -      | -      | -       |

| CONNECTION DETAILS |             |                               |
|--------------------|-------------|-------------------------------|
| REF                | FUNCTION    | DESCRIPTION                   |
| 1                  | FOOTSWITCH  | 1/4" JACK SOCKET              |
| 2                  | POWER INLET | DIN SOCKET                    |
| 3                  | WATER INLET | 8MM (5/16") OD TUBE CONNECTOR |
| 4                  | USB         | USB PORT                      |

| UNIT WEIGHTS             |                 |
|--------------------------|-----------------|
| PURELAB flex 1           | 10kg (22.0lb)   |
| PURELAB flex 1 (WITH PP) | 10.5kg (23.1lb) |
| PURELAB flex 2           | 11kg (24.2lb)   |

| ELECTRICAL REQUIREMENTS |                        |
|-------------------------|------------------------|
| MAINS INPUT             | 100-240V a.c., 50-60Hz |
| SYSTEM VOLTAGE          | 24Vdc                  |
| POWER CONSUMPTION       | 110va                  |
| NOISE LEVEL             | <40dBa                 |

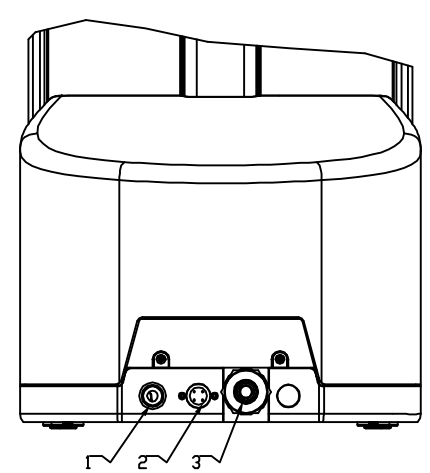
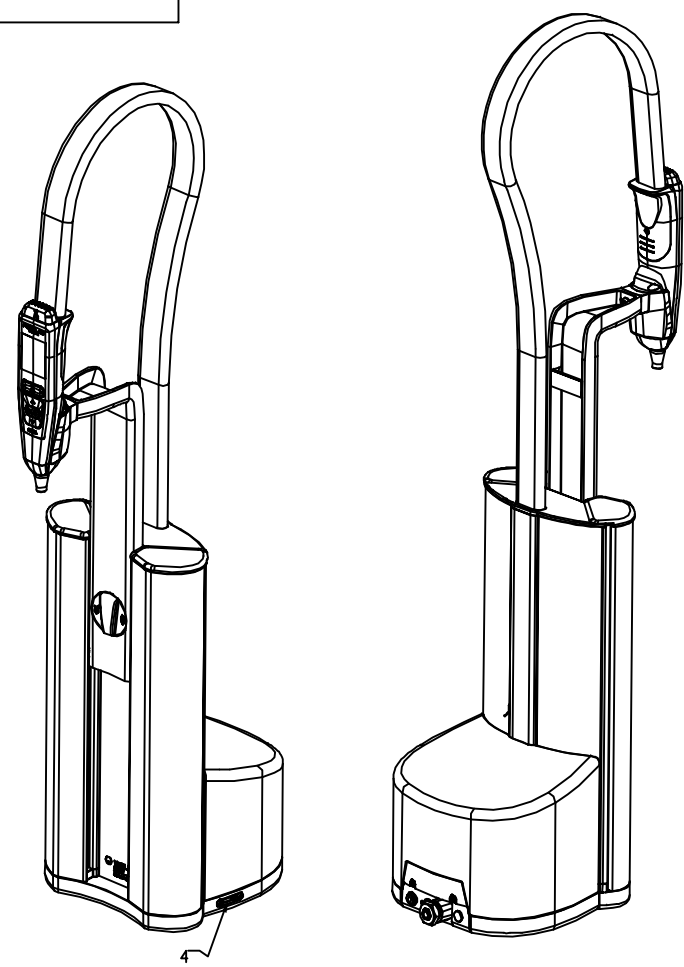
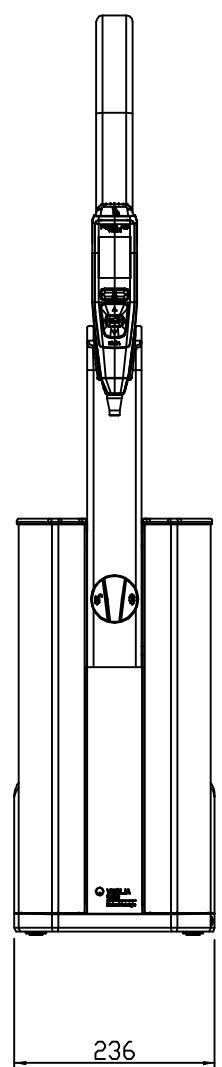
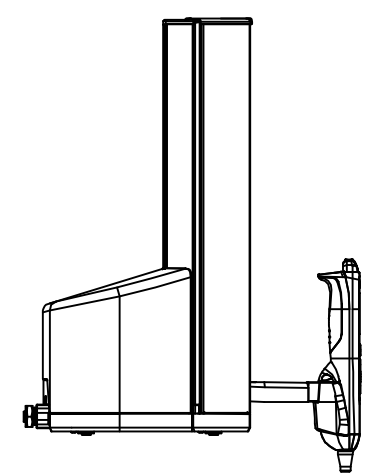
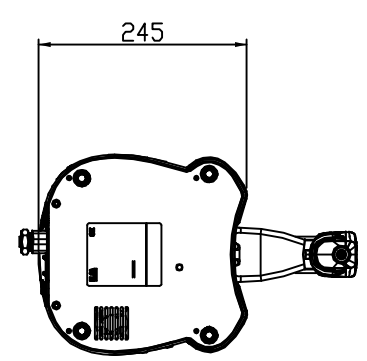
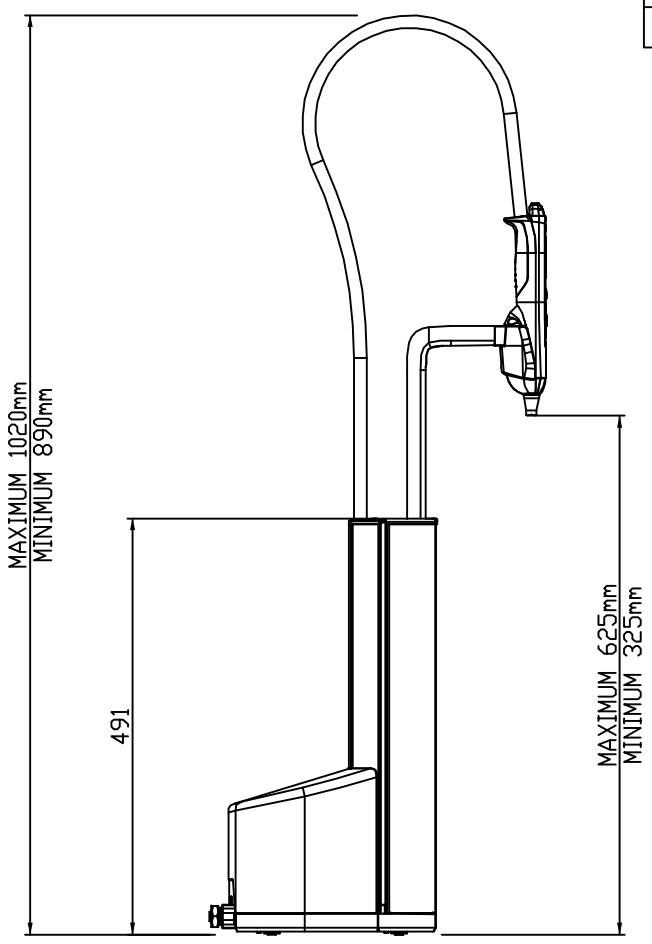
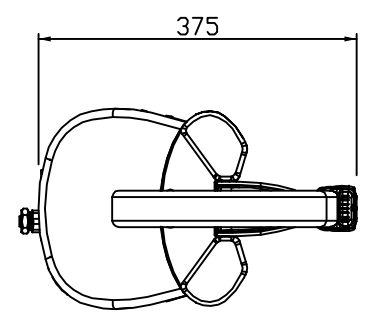

CONNECTION DETAILS

| IF IN DOUBT-ASK                   |        |                               |     |         |
|-----------------------------------|--------|-------------------------------|-----|---------|
|                                   |        |                               |     |         |
| 3rd ANGLE PROJECTION DO NOT SCALE |        |                               |     |         |
| MATERIAL: N/A                     |        |                               |     |         |
| FINISH: N/A                       |        |                               |     |         |
| GENERAL NOTE: N/A                 |        |                               |     |         |
| TOLERANCES UNLESS STATED:         |        |                               |     |         |
| ONE PLACE DEC. ± N/A              |        | ANGULAR ± 0.5°                |     |         |
| TWO PLACE DEC. ±                  |        | ALL HOLE TOLS. TO BS.4500 H11 |     |         |
| DIMS. IN mm                       | SCALE  | DRAWN                         | DSS | SEPT 11 |
| SIZE: A3                          | N.T.S. | CHECKED                       | SB  | SEPT 11 |
|                                   |        | APPROVED                      | LU  | SEPT 11 |
| DATE                              |        |                               |     |         |

TITLE  
**SALES DIAGRAM**  
**PURELAB flex 1 & 2**

PART NUMBER: N/A

**ELGA**  
[www.elgalabwater.com](http://www.elgalabwater.com)  
[info@elgalabwater.com](mailto:info@elgalabwater.com)

ELGA is the laboratory water brand of Veolia Water Solutions & Technologies.

DRG. NO. **SD-PF-1\_2** ISSUE  
 SHEET No.1 OF 2 **6**

THIS DRAWING IS THE PROPERTY OF ELGA Labwater. THE DETAILS SHOWN ARE STRICTLY CONFIDENTIAL AND MUST NOT BE DISCLOSED TO ANY THIRD PARTY WITHOUT THE CONSENT OF VWS (UK) LTD.